

# LIND LUXURY

120cm

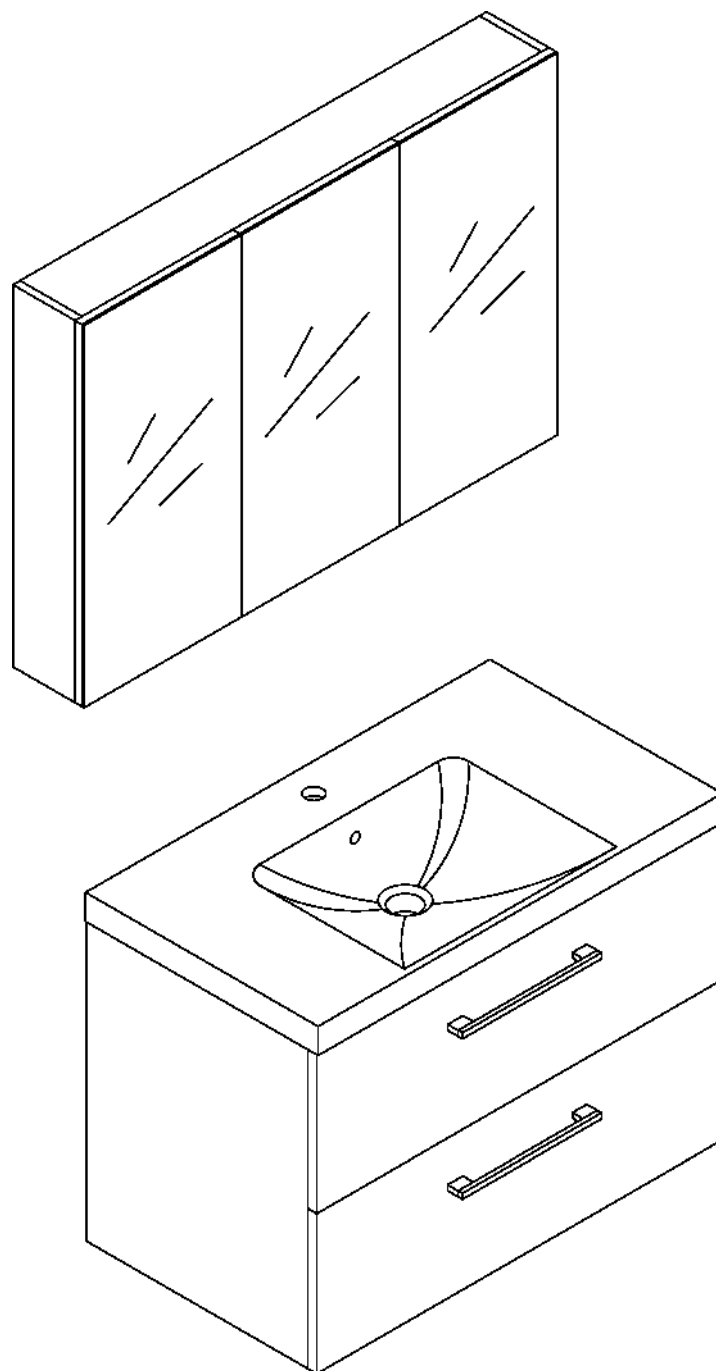

NO

**Takk for at du valgte et LIND badromsmøbel. Før du starter monteringen av dette produktet, er det viktig at du skaffer deg oversikt over alle delene. Sett av god tid til å gjøre deg kjent med hvordan monteringen skal utføres.**

Det kan være en fordel å være to personer under monteringen. Husk å kontrollere at alle deler er hele før du begynner. Dersom du oppdager riper eller skader på produktet, må dette meldes til oss umiddelbart.

Beskytt møbelet godt under montering for å unngå skader på overflater og kanter. Sørg for at glass, andre møbelflater og hjørner ikke kommer i kontakt med ståldetaljer, murverk, vegg- og gulvfliser eller andre harde overflater under montering og bruk.

SE

**Tack för att du valde ett LIND badrumsmöbel. Innan du börjar montera denna produkt är det viktigt att du skaffar dig en översikt över alla delar. Avsätt gott om tid för att sätta dig in i hur monteringen ska utföras.**

Det kan vara en fördel att vara två personer vid monteringen. Kom ihåg att kontrollera att alla delar är hela innan du börjar. Om du upptäcker repor eller skador på produkten måste detta rapporteras till oss omedelbart.

Skydda möbeln väl under monteringen för att undvika skador på ytor och kanter. Se till att glas, andra möbelytor och hörn inte kommer i kontakt med metall detaljer, murverk, vägg- och golvplattor eller andra hårda ytor under montering och användning.

EN

**Thank you for choosing a LIND bathroom cabinet. Before you begin assembling this product, it is important that you familiarize yourself with all the parts. Take your time to understand how the assembly should be carried out.**

It may be beneficial to have two people during assembly. Remember to check that all parts are intact before starting. If you discover any scratches or damage to the product, this must be reported to us immediately.

Protect the furniture carefully during assembly to avoid damage to surfaces and edges. Ensure that glass, other surfaces, and corners do not come into contact with metal parts, masonry, wall or floor tiles, or other hard surfaces during assembly and use.

Advarsel



Varning



Warning

NO

***Møbler som ikke er korrekt montert og sikret, kan velte eller falle ned. I enkelte tilfeller kan dette føre til alvorlige personskader. For å redusere risikoen for slike hendelser, skal dette møbelet installeres og festes i henhold til anvisningene.***

Vurder hvor egnet veggen er, for å være sikker på at festemidlene vil tåle kreftene de vil bli utsatt for. Bruk skrue(r) og plugg(er) som er egnet til både veggtypen og den forventede vektbelastningen. Rådfør deg med fagfolk dersom du er usikker. Les og følg alle trinn i monteringsveiledningen nøye.

SE

***Möbler som inte är korrekt monterade och säkrade kan välta eller falla ner. I vissa fall kan detta orsaka allvarliga personskador. För att minska risiken för sådana händelser ska denna möbel installeras och fästas enligt anvisningarna.***

Bedöm väggens lämplighet för att säkerställa att fästena klarar de krafter de kommer att utsättas för. Använd skruv(ar) och plugg(ar) som passar både vaggtypen och den förväntade belastningen. Rådgör med fackman om du är osäker. Läs och följ alla steg i monteringsanvisningen noggrant.

EN

***Furniture that is not properly assembled and secured may tip over or fall. In some cases, this can lead to serious personal injury. To reduce the risk of such incidents, this piece of furniture must be installed and fastened according to the instructions.***

Assess whether the wall is suitable to ensure that the fixings can withstand the forces they will be exposed to. Use screws and plugs appropriate for both the wall type and the expected load. Consult a professional if you are unsure. Read and follow all steps in the assembly instructions carefully.

Advarsel



Varning

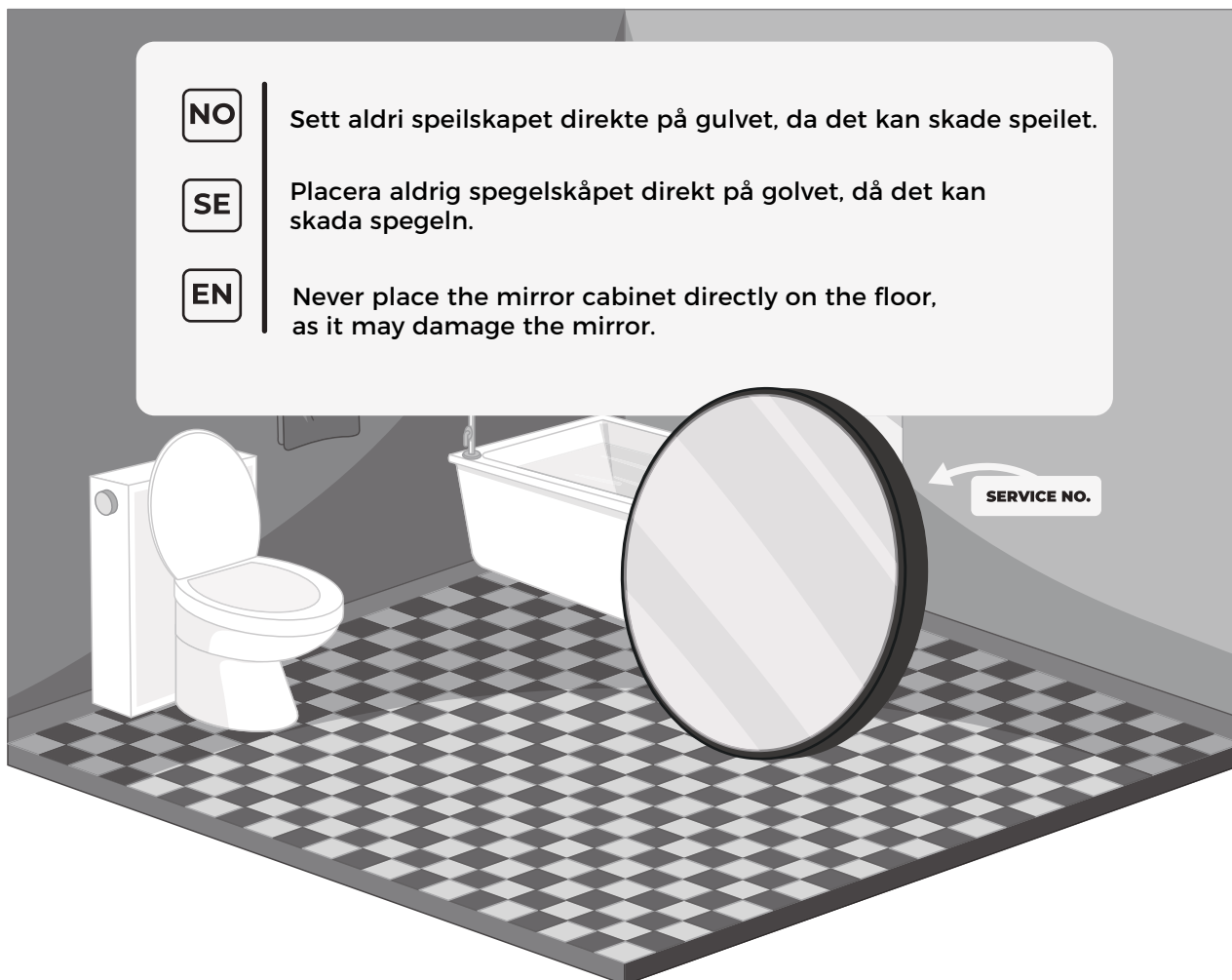

Warning

**NO**

Sett aldri speilskåpet direkte på gulvet, da det kan skade speilet.

**SE**

Placera aldrig spegelskåpet direkt på golvet, då det kan skada spegeln.

**EN**

Never place the mirror cabinet directly on the floor, as it may damage the mirror.

SERVICE NO.

**NO**

Ikke benytt skarpe gjenstander mot glassoverflaten.

**SE**

Använd inte skarpa föremål mot spegeln.

**EN**

Do not use sharp objects against the mirror glass.

**NO**

Ikke benytt sterke rengjøringsmidler på glassoverflaten.

**SE**

Använd inte starka rengöringsmedel på glasytan.

**EN**

Do not use strong cleaning agents on the glass surface.

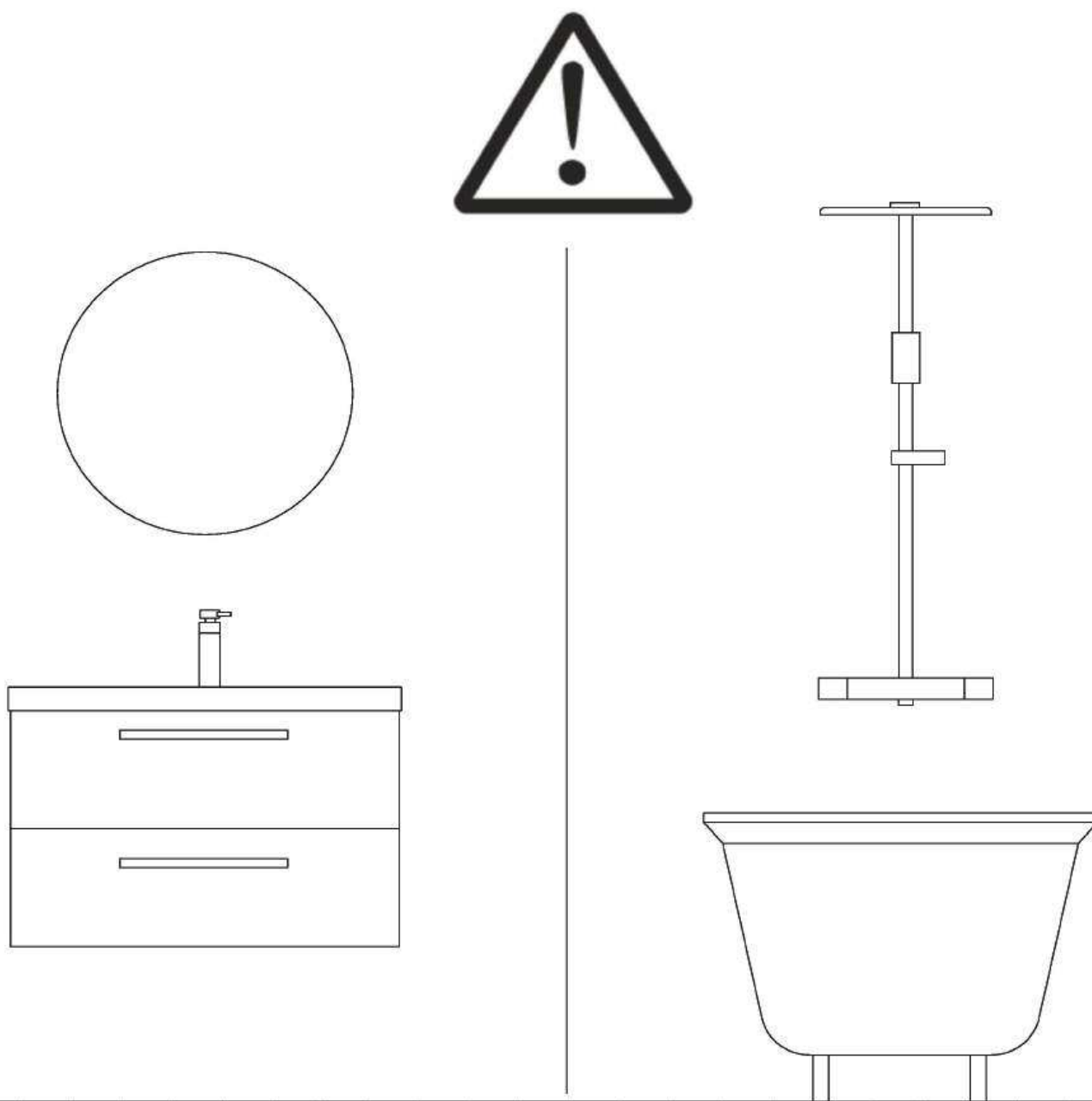
**NO**

Møbelet må monteres slik at det ikke utsettes for direkte vannsprut fra dusjsonen.

**SE**

Möbeln måste monteras utan risk för direkt vattenstänk från duschzonen.

**EN**

The furniture must be installed to avoid direct water splashes from the shower area.

Advarsel



Varning



Warning

NO

**Vedlikehold:** Rengjør møbler og servant med en myk klut og milde rengjøringsmidler uten slipemidler. Unngå sterke kjemikalier som ammoniakk, klor, syre og lignende. Servanten må ikke brukes til hårfarging eller oppskylling av klær med overskuddsfarge, da dette kan gi misfarging. Sørg for god ventilasjon i rommet, og unngå direkte vannsprut på møbelet over tid.

SE

**Underhåll:** Rengör möbler och tvättställ med en mjuk trasa och milda rengöringsmedel utan slipmedel. Undvik starka kemikalier såsom ammoniak, klor, syra och liknande. Tvättstället får inte användas för hårfärgning eller sköljning av kläder med överskottsfärg, då detta kan orsaka missfärgning. Se till att rummet är väl ventilerat och undvik direkt stänk av vatten på möbeln över tid.

EN

**Maintenance:** Clean furniture and basin with a soft cloth and mild cleaning agents without abrasives. Avoid strong chemicals such as ammonia, chlorine, acid, and similar substances. The basin must not be used for hair dyeing or rinsing clothes with excess dye, as this may cause discoloration. Ensure good ventilation in the room and avoid direct water splashes on the furniture over time.



**NB!**

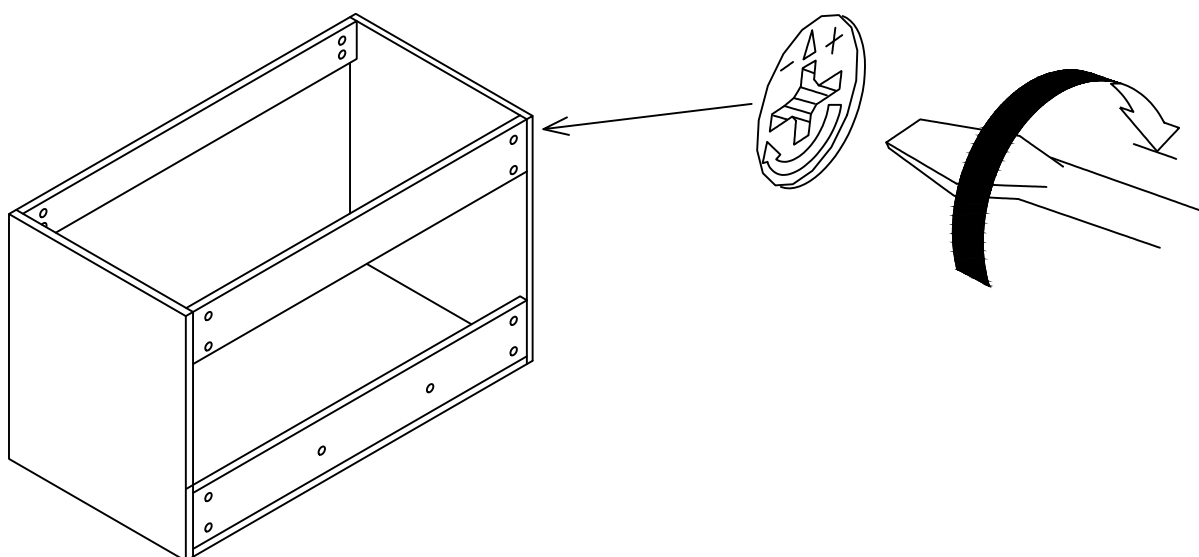

**NO**

Etterstram festeskruene før montering.

**SE**

Efterdra fästskruvarna före montering.

**EN**

Tighten the mounting screws before installation.

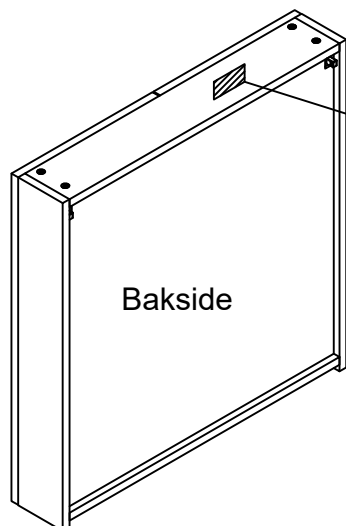

Speilskap

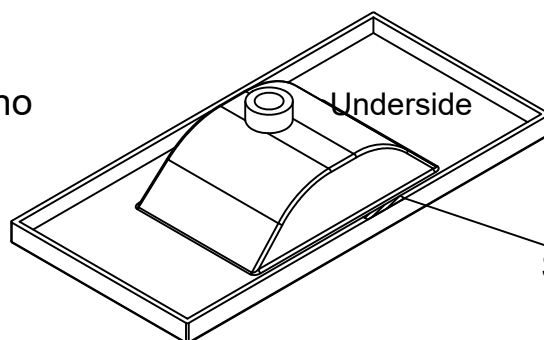

Servant

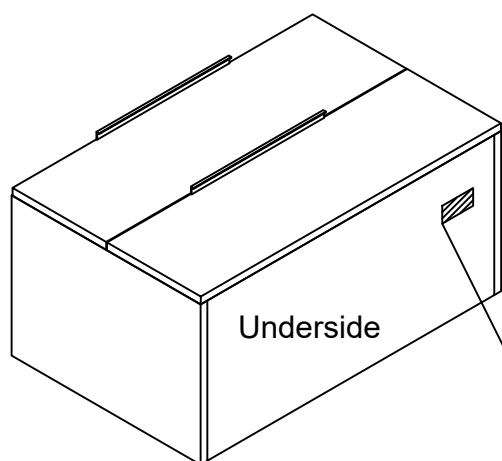

Møbelskap

- NO** | Servicenummeret må ikke fjernes.
- SE** | Servicenummeret får inte tas bort.
- EN** | The service number should not be removed.

**NO** LISTE OVER MEDFØLGENDE DELER

**SE** LISTA ÖVER MEDFÖLJANDE DELAR

**EN** SUPPLIED PARTS LIST

E1



X 8

F1



X 8

J2

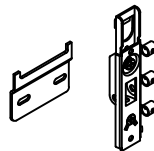

X 2

E4



X 4

F4



X 4

J3

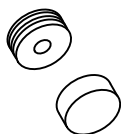

X 2

J4

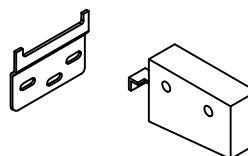

X 2

J5

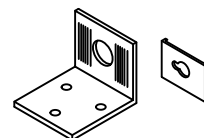

X 2

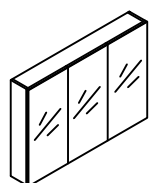

X 1

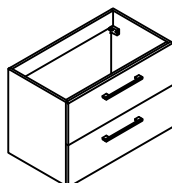

X 1

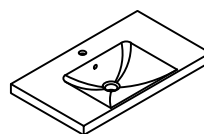

X 1

**NO** NØDVENDIG VERKTØY (IKKE INKLUDERT)

**SE** NÖDVÄNDIGA VERKTYG (INGÅR EJ)

**EN** TOOLS REQUIRED (NOT SUPPLIED)



- Blyant
- Blyertspenna
- Pencil



- Boremaskin
- Borrmaskin
- Drill



- Vater
- Vattenpass
- Level



- Limpistol
- Limpistol
- Glue gun



- Målebånd
- Måttband
- Measuring Tape



- Skrutrekker
- Skruvmejsel
- Screwdriver



- Gummiklubbe
- Gummiklubba
- Rubber mallet

- NO** | **OVERFLATEMONTERING**
- SE** | **YTMONTERING**
- EN** | *SURFACE MOUNT* **INSTALLATION**

- NO** Bor skruhellene horisontalt. Sett inn veggpluggene (F1). Fest skåpet med skruer (E1).
- SE** Borra skruvhålen horisontellt. Sätt i väggpluggarna (F1). Fäst skåpet med skruvar (E1).
- EN** Drill the screw holes horizontally. Insert the wall plugs (F1). Fasten the cabinet with screws (E1).

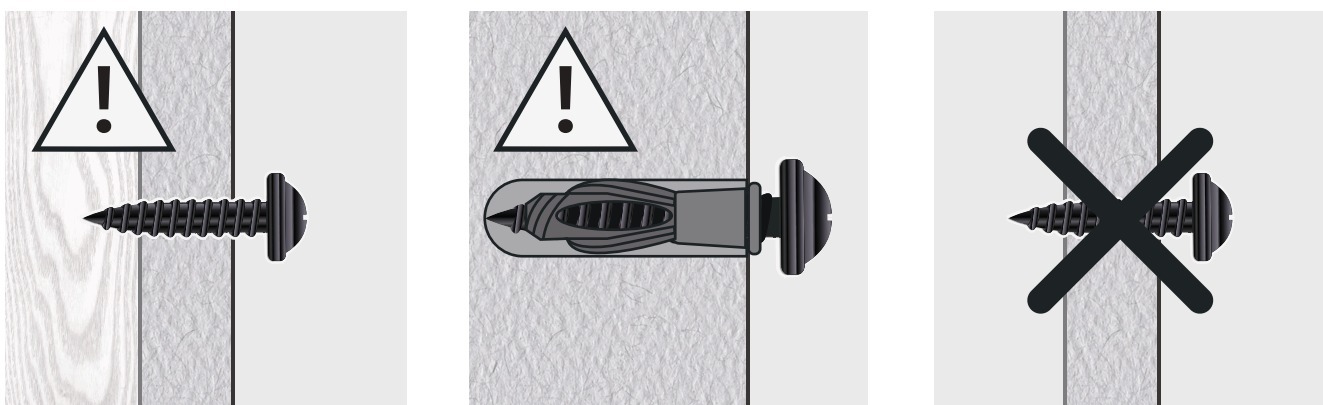

- NO** Bruk alltid skrue(r) og plugg(er) som er egnet for både veggtypen (f.eks. gips-, betong- eller trevegg) og den forventede vektbelastningen.
- SE** Använd alltid skruv(ar) och plugg(ar) som är lämpliga för både väggtypen (t.ex. gips-, betong- eller trävägg) och den förväntade belastningen.
- EN** Always use screws and wall plugs suitable for both the wall type (e.g. drywall, concrete or wooden wall) and the expected load.

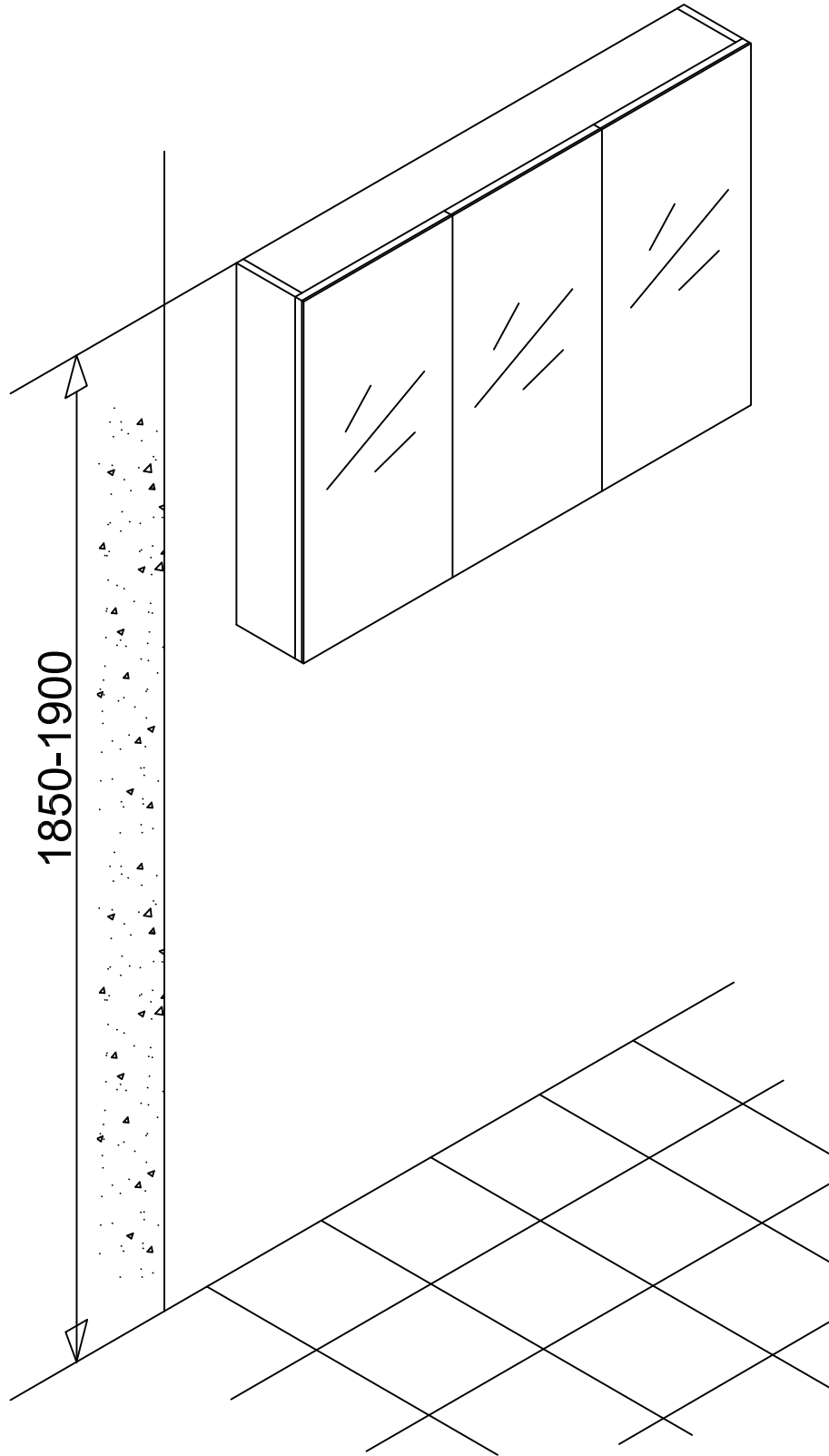

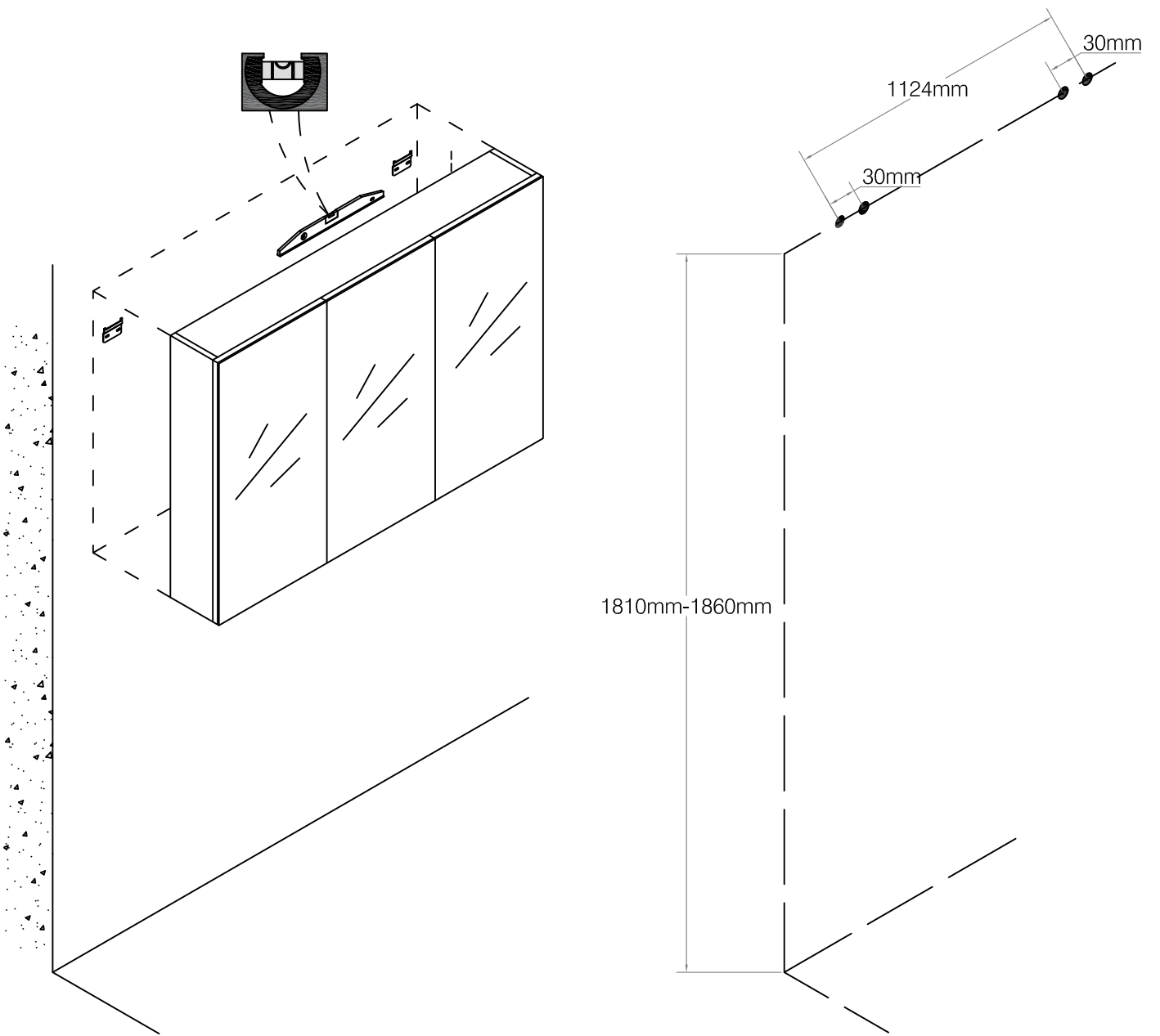

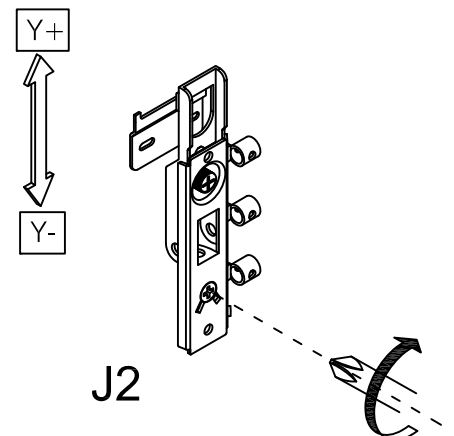
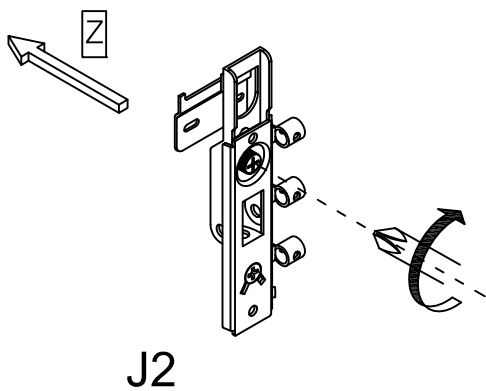
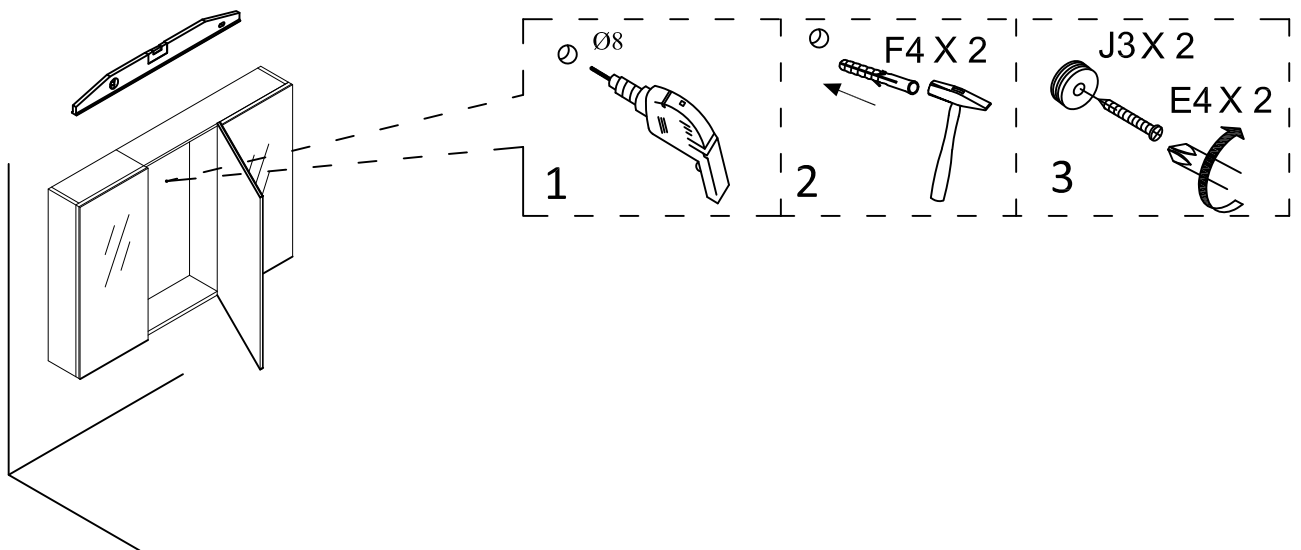
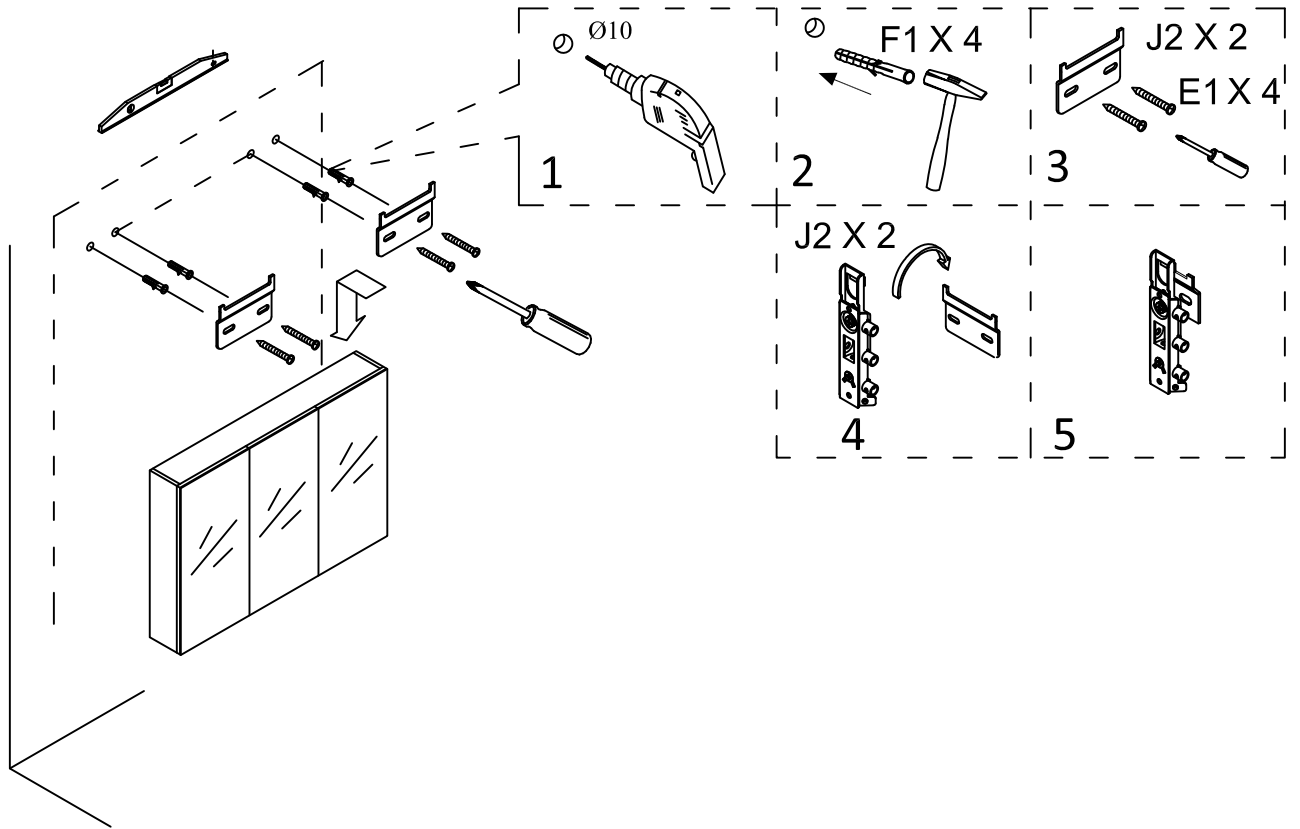

120cm

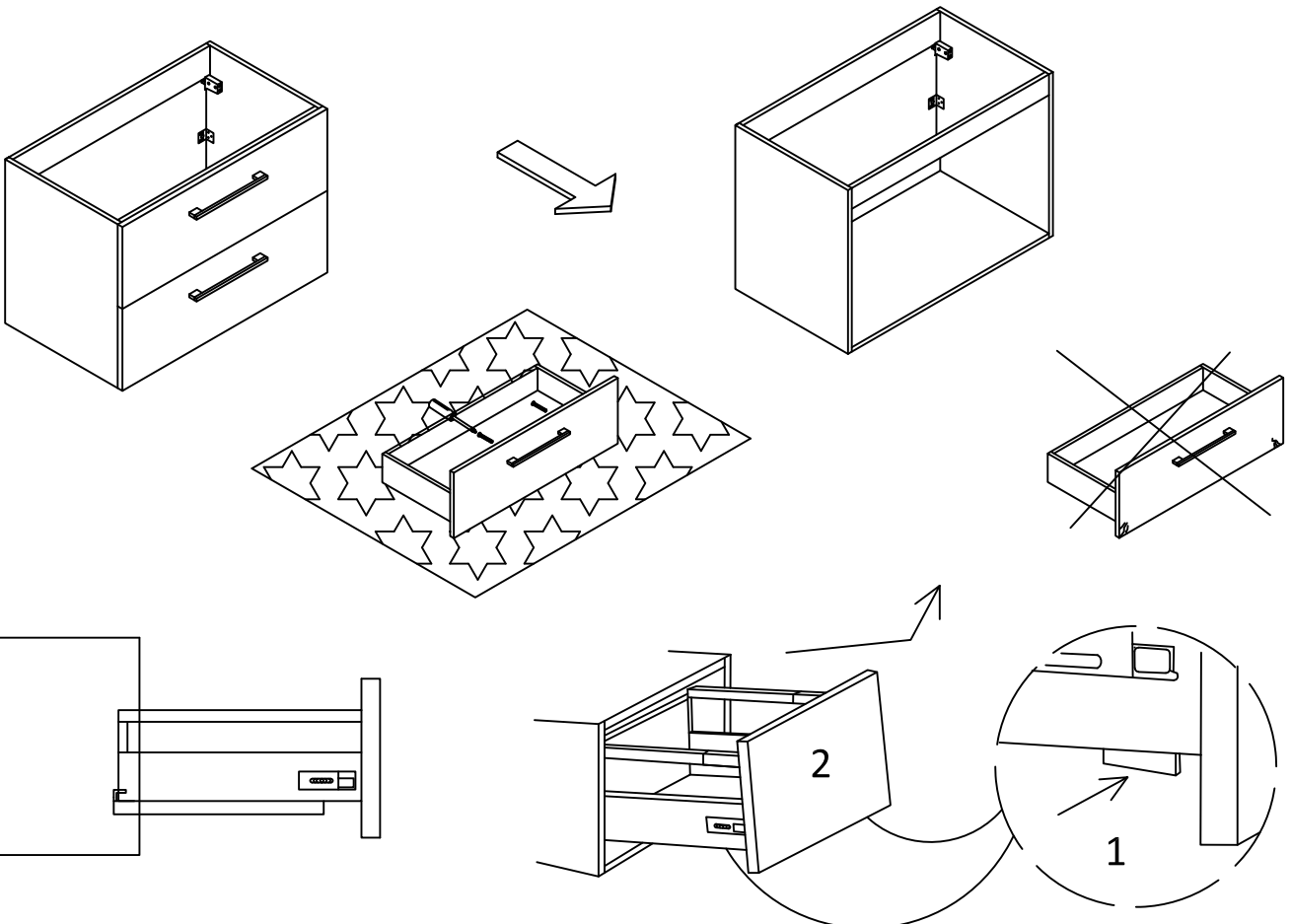
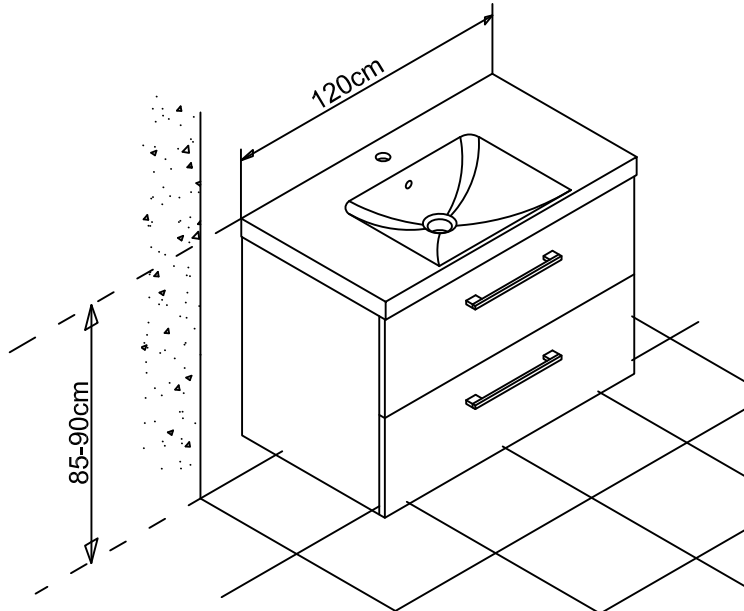

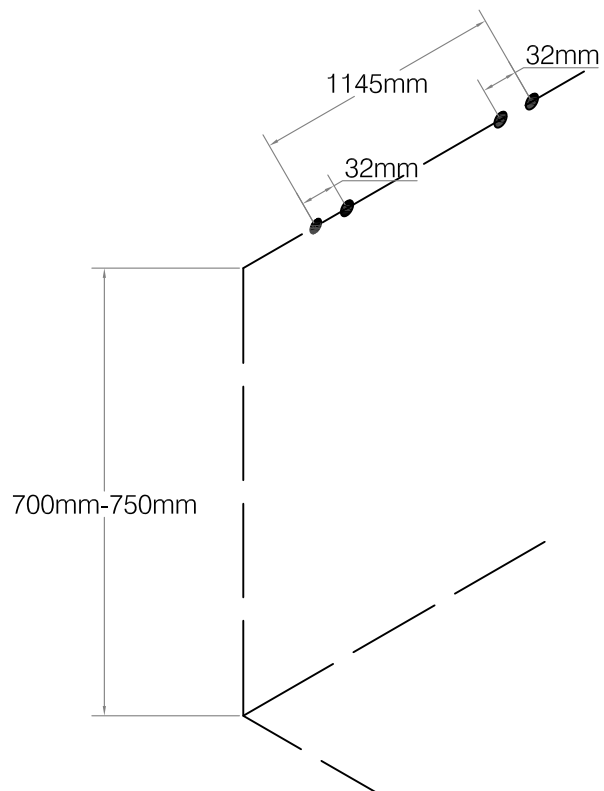
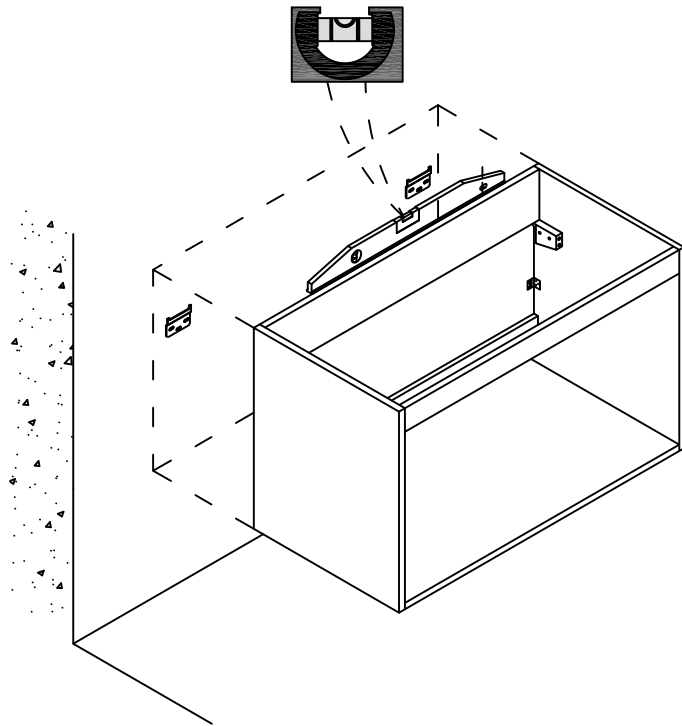

**120cm**

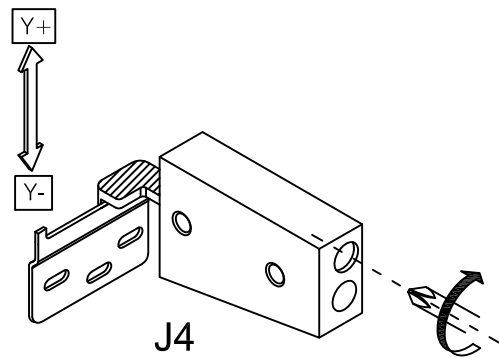
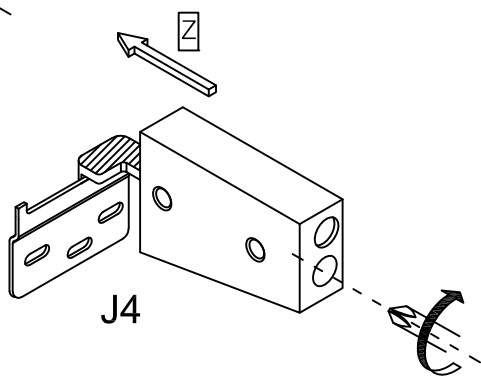
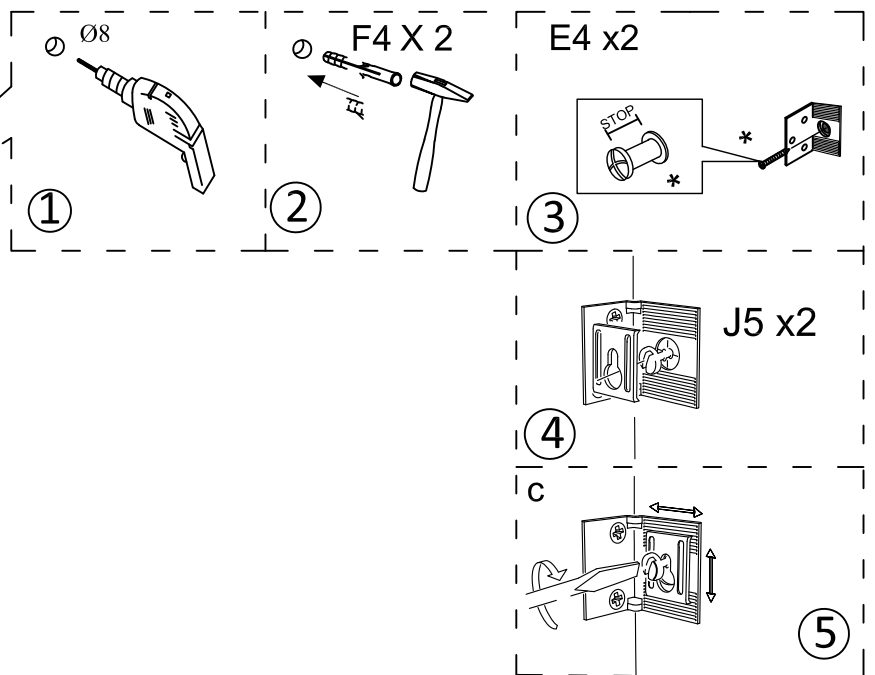
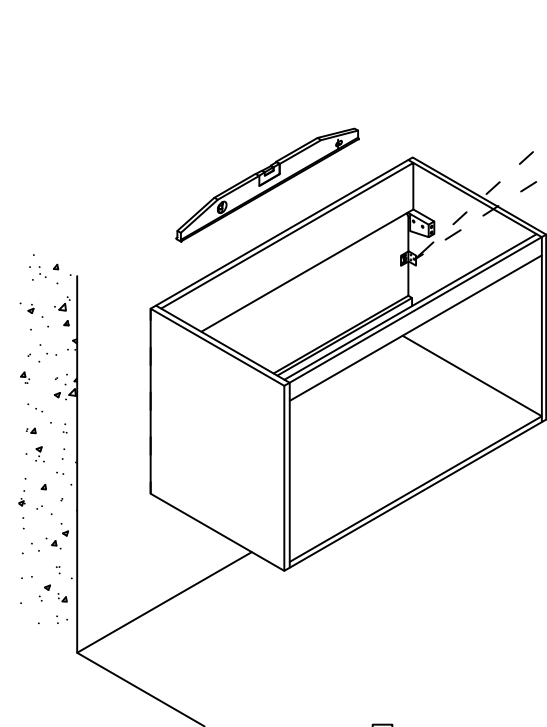
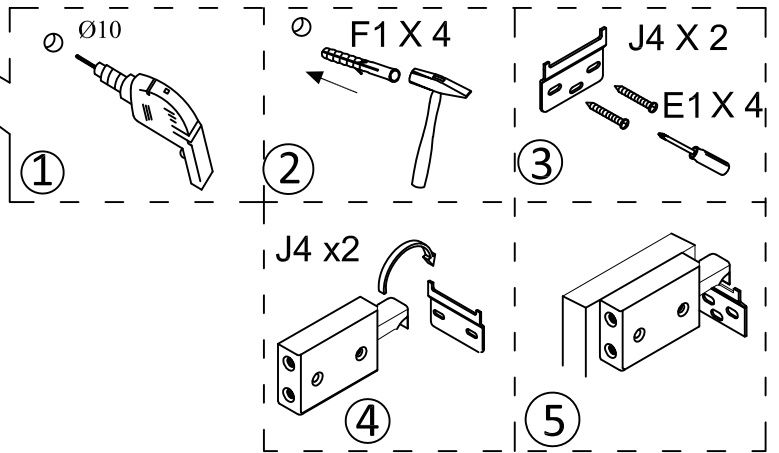
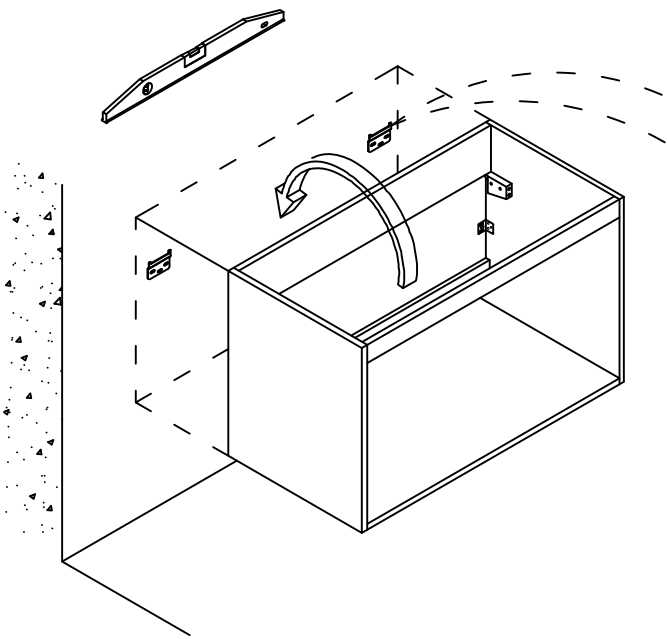

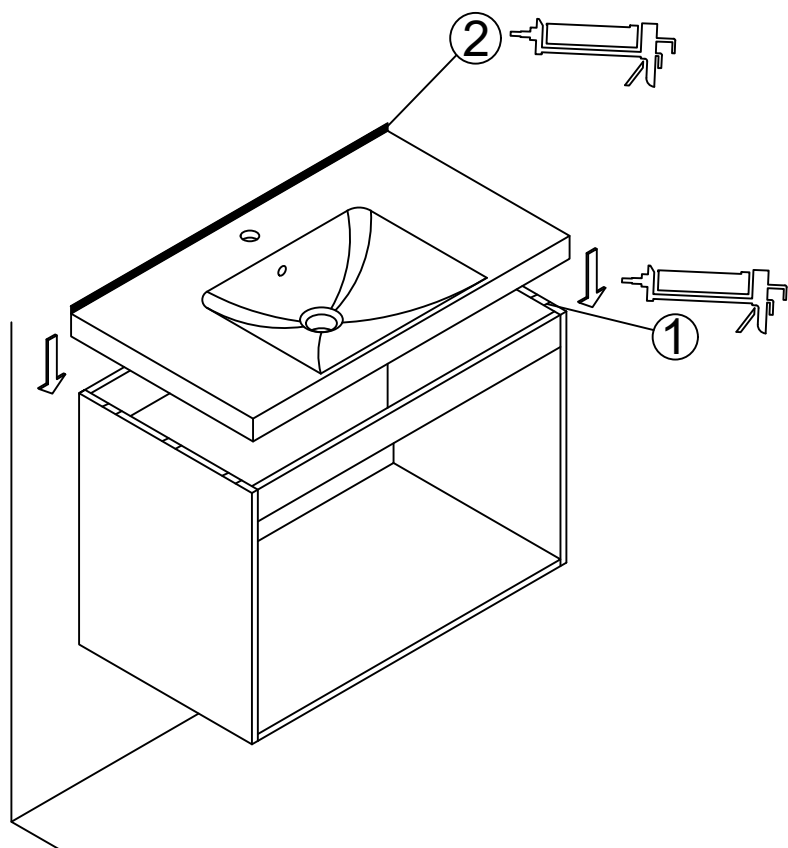

**NO** Påfør 3 punkter transparent silikon på sidene av møbelet samt en stripe på bakside og topp av servanten.

**SE** Applicera 3 punkter av transparent silikon på sidorna av möblet samt en remsa på baksidan och på toppen av tvättstället.

**EN** Apply 3 dots of transparent silicone on the sides of the furniture and 1 strip on the back and top of the basin.

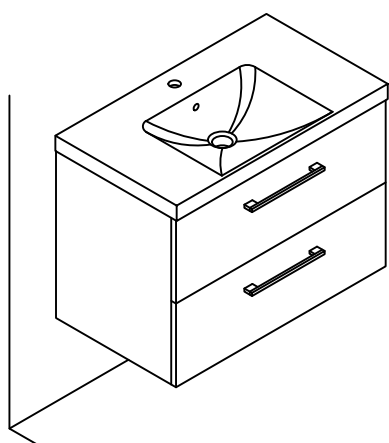
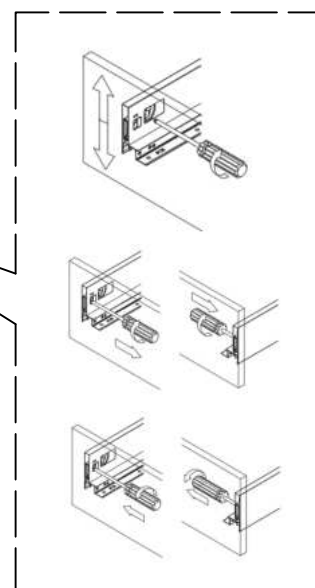
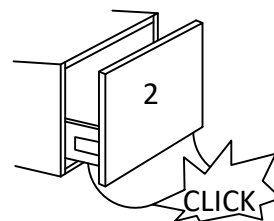
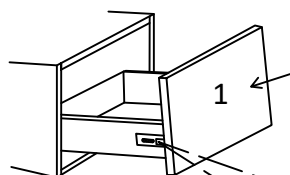
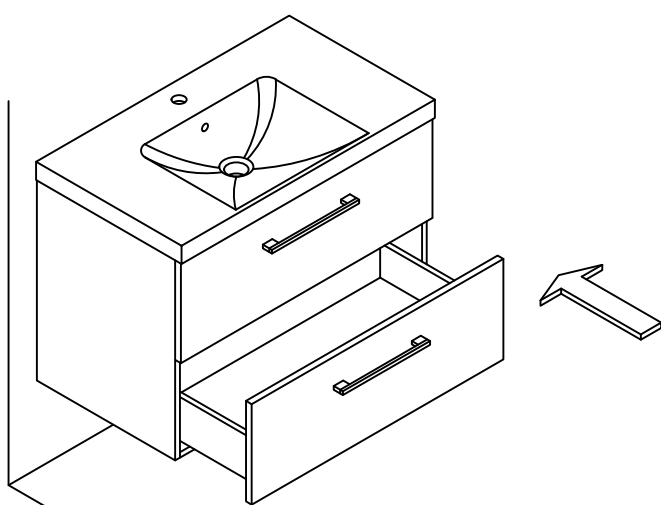

## RESERVEDELER

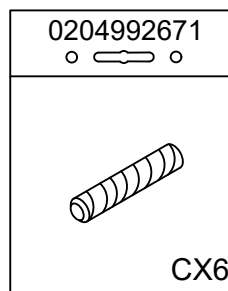
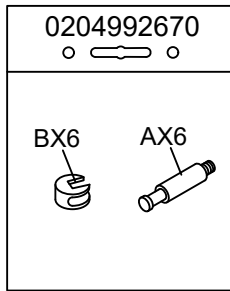
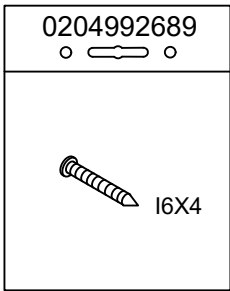
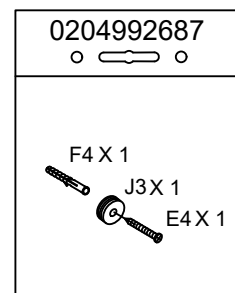
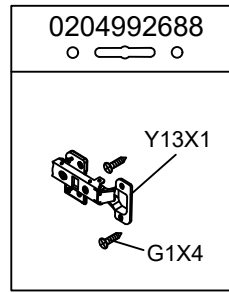
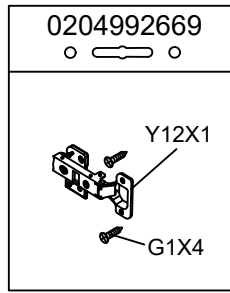
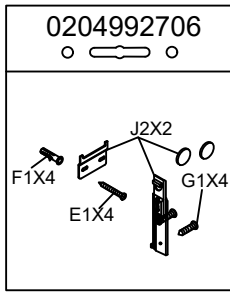

## RESERVEDELER TILGJENGELIG FOR BESTILLING

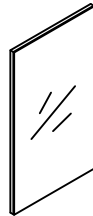

Venstre speildør

Varenummer	Bestillingsnummer
Y544-120G	022743
Y544-120B	022739
Y544-120W	022745



Midtre speildør

Varenummer	Bestillingsnummer
Y544-120G	022744
Y544-120B	022740
Y544-120W	022746

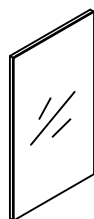

Høyre speildør

Varenummer	Bestillingsnummer
Y544-120G	022742
Y544-120B	022741
Y544-120W	022612

## RESERVEDELER

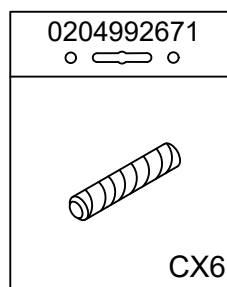
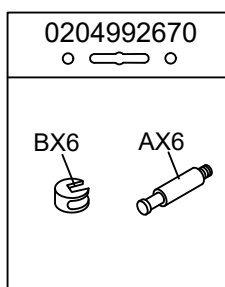
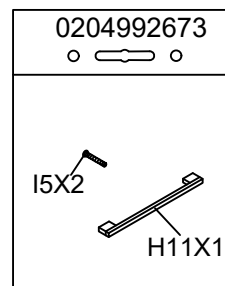
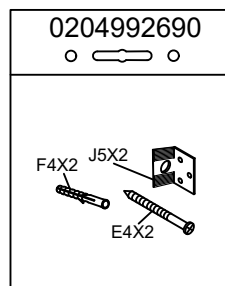
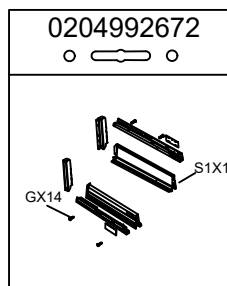
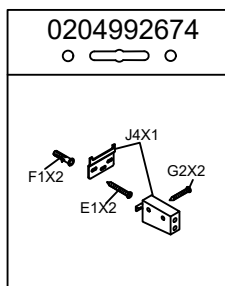

## RESERVEDELER TILGJENGELIG FOR BESTILLING

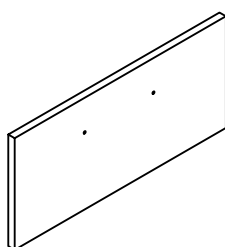

øvre skuffefront

Varenummer	Bestillingsnummer
Y544-120SG	022784
Y544-120SB	022622
Y544-120SW	022783

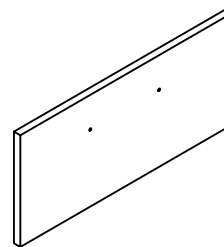

nedre skuffefront

Varenummer	Bestillingsnummer
Y544-120SG	022782
Y544-120SB	022780
Y544-120SW	022781